

# 8 PARTS MANUAL

## 8.1 LIFT ASSEMBLY

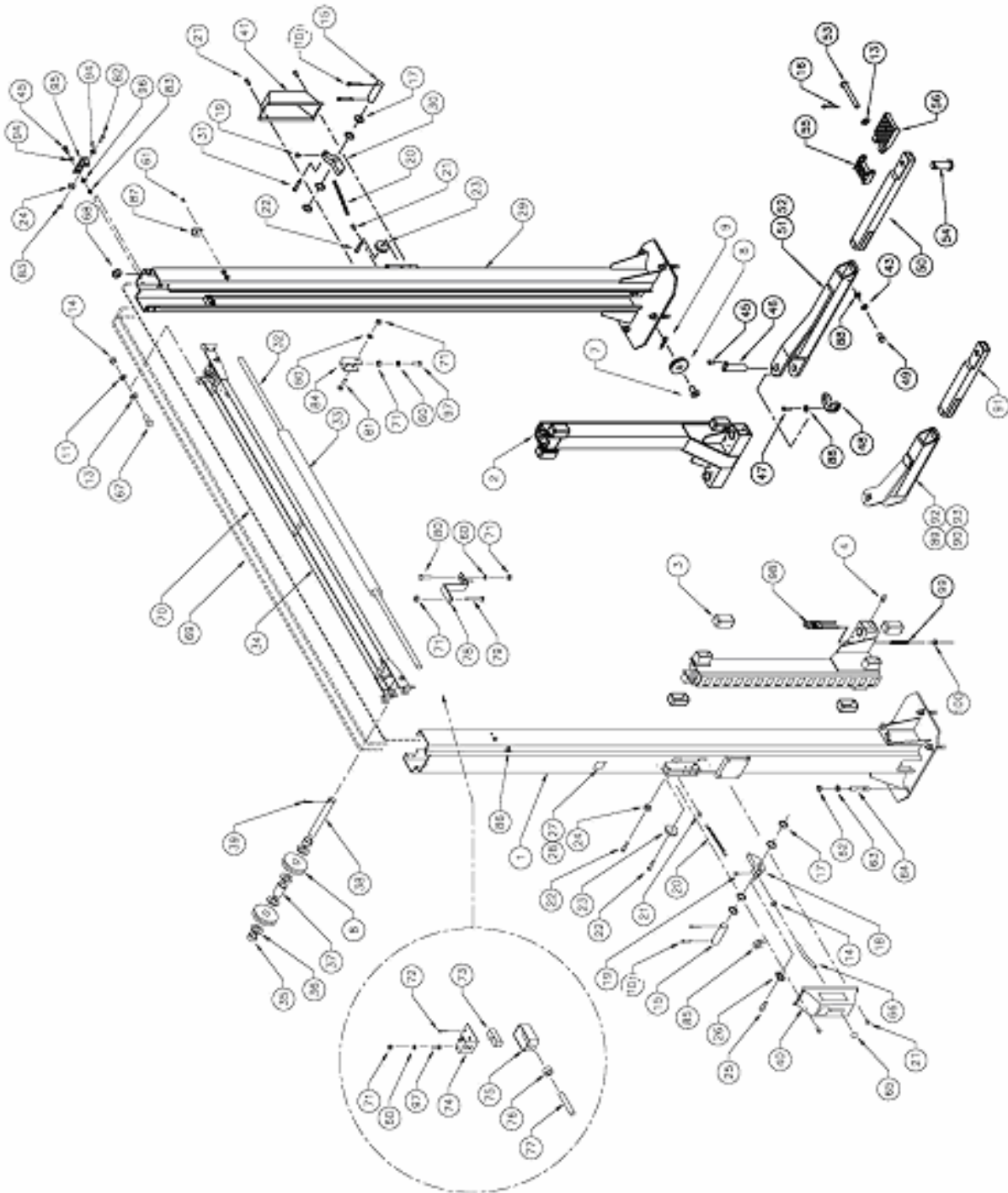

## 8.2 LIFT ASSEMBLY PARTS LIST

ITEM	QTY	DESCRIPTION	PART #
1	1	TOWER WELDMENT, POWER SIDE	4-0767
2	2	CARRIAGE WELDMENT	4-1114
3	8	GLIDE BEARING	2-0772
4	4	GREASE NIPPLE	6-0000
7	2	PIN, CABLE EQUALIZATION	1-1887
8	6	2-POST PULLEY	1-1898
9	2	HITCH PIN, 1/8" DIA	6-1841
11	8	LOCKWASHER, 1/2"ID	6-0059
13	12	FLAT WASHER, 1/2"ID SAE	6-0248
14	13	HEX NUT, 1/2"-13UNC	6-0035
15	2	SAFETY PIN	1-2337
16	4	COTTER PIN, 1/8"DIA. x 1"LG.	6-0267
17	8	FLAT WASHER, 5/164"ID x 1"OD x 1/16"THK.	6-0808
18	1	SAFETY DOG WELDMENT, POWER SIDE	2-1901
19	4	SELF TAPPING SCREW, #10 X 3/8" LG.	6-0169
20	2	SAFETY SPRING	1-1115
21	6	SELF TAPPING SCREW, #12 x 1/2"LG.	6-1134
22	3	SHOULDER BOLT, 3/8"DIA. x 1"LG.	6-0206
23	2	SAFETY PULLEY	1-0415
24	3	SAFETY CABLE PULLEY	1-1116
25	1	SHOULDER BOLT, 3/8" x 1 1/2" LG.	6-0801
26	1	THIMBLE, 5/32"	6-2074
27	1	CAPACITY DECAL	6-1767
28	1	SERIAL PLATE	6-1111
29	1	TOWER WELDMENT, SLAVE SIDE	4-0768
30	1	SAFETY DOG, SLAVE SIDE	2-0872
31	1	SHOULDER BOLT, 3/8"DIA. x 1 1/2"LG.	6-0801
32	1	ACTUATOR BAR	1-1380
33	1	FOAM GUARD	6-1404
34	1	CROSSMEMBER WELDMENT	3-0694
35	4	CROSSMEMBER PULLEY PIPE, 1/2"LG.	1-1623
36	8	FLAT WASHER, 3/4"ID	6-0738
37	2	CROSSMEMBER PULLEY PIPE, 1 3/4"LG.	1-1626
38	2	CROSSMEMBER PULLEY SHAFT	2-1252
39	2	COTTER PIN, 1/8"DIA. x 1 1/2"LG.	6-0978
40	1	SAFETY COVER cw/DECALS, POWER SIDE	0-0204
41	1	SAFETY COVER cw/DECALS, SLAVE SIDE	0-0203
43	4	LOCKWASHER, 3/8" ID	6-0058
45	8	HEX BOLT, 5/16"-18UNC x 3/4" LG.	6-0423
46	4	ARM PIN	2-1594
47	4	HEX BOLT 5/16-18 UNC x 1-1/4 LG.	6-2059
48	4	ARM RESTRAINT GEAR	1-2618
49	4	HEX BOLT, 3/8UNCx3/4"LG.	6-0030
50	2	INNER ARM WELDMENT (LONG)	3-0924

ITEM	QTY	DESCRIPTION	PART #
51	2	OUTER ARM WELDMENT (LONG)	3-0920
52	2	ARM ASSEMBLY (LONG)	4-1118
53	4	CENTER PIN	1-1099
54	4	ADAPTER PIN	1-2953
55	4	LOW POSITION ADAPTER	3-0583
56	4	HIGH POSITION ADAPTER	3-0582
60	6	LOCKWASHER, 1/4" ID	6-0056
61	6	ROUND HEAD SCREW, 1/4"-20UNC x 3/8" LG.	6-1353
62	10	HEX NUT, 3/4"-10UNC	6-0737
63	10	FLAT WASHER, 3/4"ID	6-0738
64	10	WEDGE ANCHOR, 3/4"-10UNC x 5 1/2"LG.	6-1379
65	1	PLASTIC KNOB	6-1135
66	1	SAFETY RELEASE HANDLE	1-1113
67	8	HEX BOLT, 1/2"-13UNC x 1 1/4" LG.	6-0046
68	3	RUBBER GROMMET	6-1507
69	2	EQUALIZING CABLE	1-1786
70	1	SAFETY RELEASE CABLE	1-2058
71	7	HEX HD. NUT 1/4"NC	6-0032
72	2	6/32 SCREW (ELECTRICAL BOX)	6-1466
73	1	MICROSWITCH	6-0916
74	1	LIMIT SWITCH MTG. BRACKET	2-1143
75	1	ELECTRICAL UTILITY BOX	6-1403
76	1	CABLE CONNECTOR	6-1133
77	1	ELEC. CABLE 12/3 x 117"LG.	6-1173
78	1	ACTUATOR EXTENSION	1-1379
79	1	HEX HD. BOLT 1/4"NC x 2"LG.	6-0741
80	2	HEX HD. BOLT 1/4"NC x 1 1/4"LG.	6-0027
81	1	HEX HD. BOLT 1/4"NC x 1 1/2"LG.	6-0205
82	2	SHOULDER BOLT, 3/8"DIA. x 5/8"LG.	6-0069
83	6	HEX NUT, 5/16"-18UNC	6-0294
84	1	ACTUATOR MTG. BRACKET	1-1378
85	2	WIRE ROPE CLIP, 1/16"	6-2060
86	3	ELECTRICAL CABLE CLIP, 5/8" ID	6-1759
87	6	TUBE CLAMP, 1/2"	6-0536
88	16	FLATWASHER, 3/8"ID SAE	6-0062
89	1	OUTER ARM WELDMENT (SHORT- R.S.)	3-0922
90	1	OUTER ARM WELDMENT (SHORT - L.S.)	3-0921
91	2	INNER ARM WELDMENT (SHORT)	3-0925
92	1	ARM ASSEMBLY (SHORT - R.S.)	4-1120
93	1	ARM ASSEMBLY (SHORT - L.S.)	4-1119
94	6	LOCKWASHER, 5/16"ID	6-0296
95	2	PULLEY BRACKET	2-1477
96	4	FLATWASHER, 5/16"ID	6-0295
97	3	HEX BOLT 1/4-20 x 3/4 LG.	6-1078
98	4	ARM LOCK HANDLE WELDMENT	1-2914
99	4	ARM LOCK SPRING	1-2942
100	4	SPRING RETAINER CAP	6-3086
101	4	SNAP RING 3/4" EXT	6-2445

### 8.3 HYDRAULIC SYSTEM

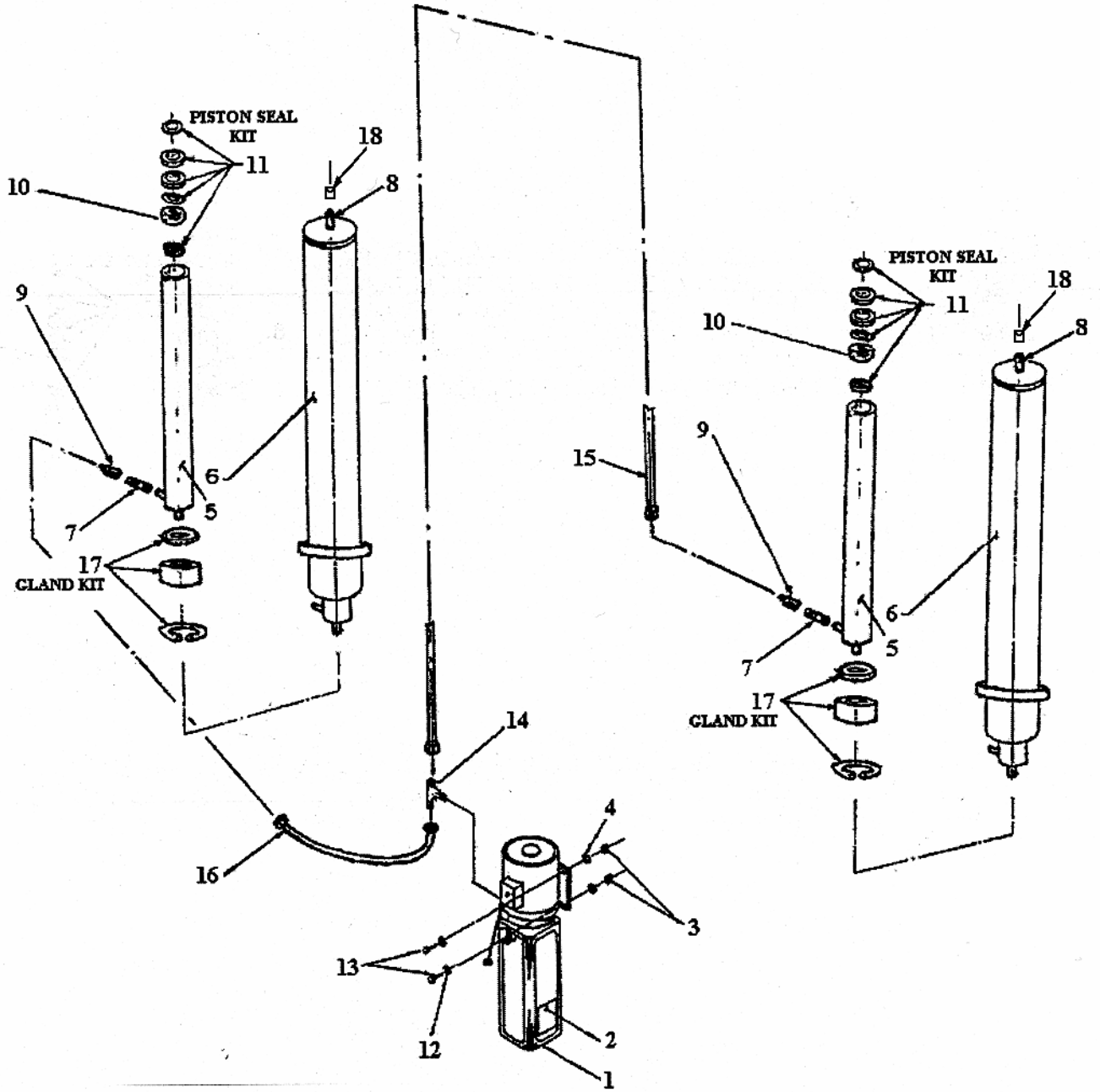

## 8.4 HYDRAULIC SYSTEM PARTS LIST

ITEM	QTY	DESCRIPTION	PART #
1	1	POWER PACK, 220V/1PH	6-2055
		POWER PACK, 220V/3PH	6-2665
2	1	"LIFT OPERATION" DECAL	6-2094
3	4	HEX NUT, 5/16"-18UNC	6-0294
4	4	LOCK WASHER, 5/16" I.D.	6-0674
5	2	PISTON ROD	2-1254
6	2	CYLINDER TUBE	2-125501
7	2	MALE NIPPLE, 1/4" NPT	6-2095
8	2	1/8" NPT TO 1/4" JIC	6-0280
9	2	FLOW CONTROL	6-1510
10	2	PISTON	1-1467
11	2	PISTON SEAL KIT	0-0337
12	4	FLAT WASHER, 5/16" I.D.	6-0295
13	4	HEX BOLT, 5/16"-18UNCx1" LG.	6-0293
14	1	BRANCH TEE	6-1506
15	1	HYDRAULIC HOSE (LONG)	2-1486
16	1	HYDRAULIC HOSE (SHORT)	2-1230
17	2	GLAND KIT	0-0338
18	2	1/4" JIC CAP	6-1884
	*	CYLINDER ASSEMBLY (NOT INCL. FLOW CONTROL)	3-062101

### 8.5 POWER PACK:

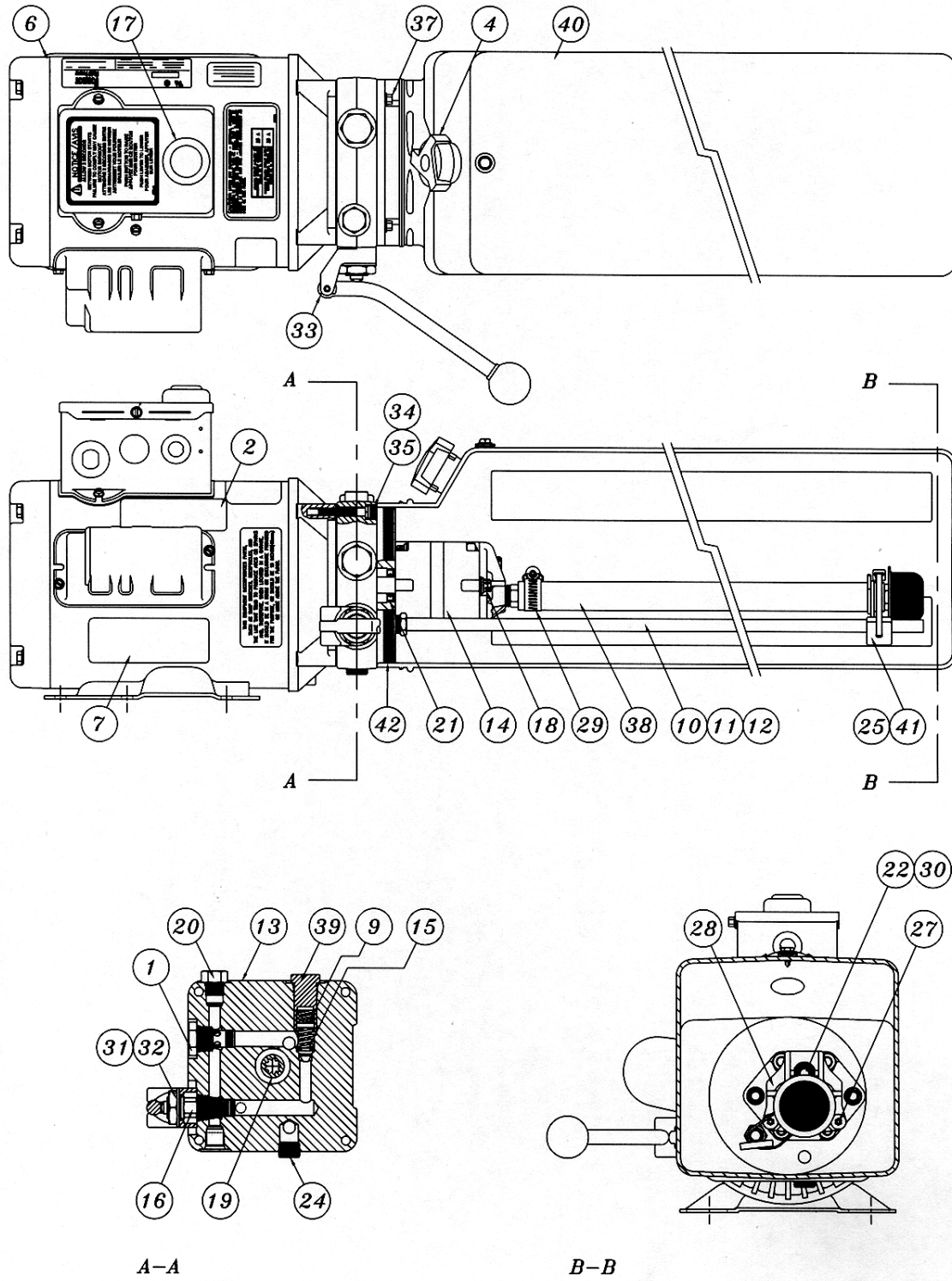

## 8.6 POWER PACK PARTS LIST:

#6-2055 (AB-1381) 208-230V/1PH/60Hz

#6-2665 (AD-1044) 208-230V/3PH/60Hz

ITEM	QTY.	DESCRIPTION	PART #
1	1	VALVE CARTRIDGE CHECK	6-1087
2	1	LABEL INSTALLATION AUTOHOIST	6-2136
4	1	BREATHER CAP & BLADDER	6-1376
6	1	MOTOR AC 208-230V. 2HP/1PH/60Hz, BLK	6-2139
	1	MOTOR AC 208-230V. 2HP/3PH/60Hz, BLK	6-1079
7	1	LABEL WARNING AUTOHOIST	6-2149
9	1	SPRING 0.480" x 0.063" x 0.42" COMP	6-2151
10	1	RETURN HOSE 3/8" OD x 21.5"	6-2152
11	1	COMPRESSION TUBE NUT	6-2153
12	1	COMPRESSION TUBE SLEEVE	6-2154
13	1	ENDHEAD UNIVERSAL AUTOHOIST	6-2155
14	1	PUMPASSY 2.5 CC/REV. SHORT SPLINE	6-1958
15	1	RELIEF ASSEMBLY FIXED 190 BAR	6-1319
16	1	VALVE CARTRIDGE RELEASE MANUAL	6-0880
17	1	WIRING ASSEMBLY AC 1PH FENNER	6-2473
18	2	BOLT 5/16"-24 x 3.00" TORX G8	6-1090
19	1	COUPLING SAE 9T-20/40 1.260"	6-0774
20	1	PLUMBING PLUG 9/16" SAE	6-2157
21	1	SEAL SHAFT 0.500" x 1.00" x 0.25"	6-2158
22	1	WASHER 0.338" x 0.625" x 0.060" STEEL	6-2159
24	1	PLUMBING PLUG 3/8" NPT	6-2161
25	1	PLUMBING MAGNET	6-2162
27	2	SCREW TAPTITE M6 x 1.0 12MM TORX	6-2164
28	1	COVER ASSY SUCTION	6-2165
29	1	PLUMBING CLAMP HOSE ADJ. INLET	6-2166
30	1	BOLT 5/16"-18 x 1.00" SHCS	6-1392
31	1	NUT 3/4"-16 x 1" HEX x 0.250" STEEL	6-2167
32	1	WASHER 3/4" INT. TOOTH LOCK	6-2168
33	1	BRACKET - HANDLE ASSY REL BLACK	6-0776
34	4	BOLT M6 x 1.0 35MM SOC HD	6-2169
35	4	WASHER 1/4" LOCK HI-COLLAR	6-2170
37	4	BOLT #12-24 x 0.50' HEX WSHRHD	6-1091
38	1	PLUMBING ASSY INLET 17.24 (3)	6-0786
39	1	RELIEF VALVE CAP ASSEMBLY	6-1089
40	1	TANK PLASTIC 6.7 OS 22.50" BLK	6-1399
41	1	CABLE TIE 8" LONG WHITE	6-1846
42	1	O-RING 2-348 BUNA	6-0875

## 8.7 LIFT MAINTENANCE GUIDELINES – CABLE EQUALIZATION

### Two Post Lifts

#### Safety Instructions

Read operating and safety manuals before using any lift  
Do not operate a lift that has been damaged or is in disrepair  
Proper inspection and maintenance is necessary for safe operation

#### *General*

Check all hydraulic lines and fittings for pinch points, damage , cracks or leaks  
Check all electrical wiring for pinch points, cracks or damage  
Check all moving parts for uneven or excessive wear  
Repair or replace all damaged, defective, worn or broken components immediately

#### Cable Equalized Two Post Lift

- clean and re-grease slide block channels inside of both columns every two months
- grease arm pins every two months
- check and lubricate safety dogs and safety cable adjustment every two months
- dismantle, clean and lubricate arm restraints every two months
- dismantle and clean inner arms every four months
- lubricate cable pulleys every four months
- check equalizing cables and adjust every four months or as required
- change hydraulic oil every two years
- periodically check anchor bolts and re-torque if required

#### Hydraulically Equalized Two Post Lift

- check and adjust hydraulic level weekly or as required
- clean and re-grease slide block channels inside of both columns every two months
- grease arm pins every two months
- check and lubricate safety dogs and safety cable adjustment every two months
- dismantle, clean and lubricate arm restraints every two months
- dismantle and clean inner arms every four months
- change hydraulic fluid every two years
- periodically check anchor bolts and re-torque if required

Lubrication : Where grease is required > multi-purpose lithium grease  
Where lubricating oil is required > multi-purpose SAE 30 lubricating oil  
Where hydraulic oil is required > ISO 32 10W - non detergent hydraulic oil

## 8.8